

15.11.2016 | PRESS RELEASE

Modular Biogas analyzer station with maintenance diagnosis - the new COMBIMASS GA-s hybrid premium



Modern analysis technology is used for process Monitoring and control in anaerobic digestion plants, landfills and biogas from sewage plants.

The typical configuration contains one sampling point directly after the digester and a second downstream to the sulphure filter respectively in front of the CHP unit. The cabinet presented at the exhibition is prepared for even this application: 2 sampling points with two gas circles. After the digester methane and hydrogen sulphide (HIGH) and in front of the CHP additionally oxygen and hydrogensulphide (LOW) is analyzed. Sulphure in the gas to the CHP is a sensitive parameter, so a second H₂S-gas module (with overload-protection in case the filter fails) with a lower operation range is used to analyze hydrogensulphide very precise.

The design of the COMBIMASS[®] GA-s hybrid premium station is completely modular. All pumps, valves and gas modules are mounted on DIN-rails for flexible design of the cabinet. So various gas streams with different concentration levels can be analyzed continuously or in time cycles. There can be several gas circles run parallel. Beside typical NDIR and electrochemical sensors also heat conductivity sensors can be used.

Data can be stored internally on an USB-stick or SD-card. They can be transferred via various bus systems or analog/digital signals. Further options like an external access for monitoring of operation, maintenance diagnosis and/or data transmission can be supplied. The analyzer cabinet and the gas are monitored for pressure and temperature level. A hardware or software key can be used to secure the configuration settings.

All gas modules can become recalibrated in the cabinet during normal operation. So a long-time accuracy can be achieved easily. Manual calibration function is supplied as a standard, but an auto-calibration software can be applied too, if a span gas bottle is connected permanently with the analyzer cabinet.

The actual status of the gas modules is displayed on the graphic display using traffic light colours: green – okay and precisely; yellow – recalibration/ maintenance is required soon; red – maintenance now. The operator can put its acceptable deviation of analysis results compared to the calibration situation into configuration settings customized. If required accuracy cannot be achieved any more after recalibration, gas modules shall be checked by and if necessary refurbished at the manufacturer. Based on the maintenance diagnosis system and the traffic light colours, time cycles for service can be adjusted to the frequency of use as well as requirements on accuracy.

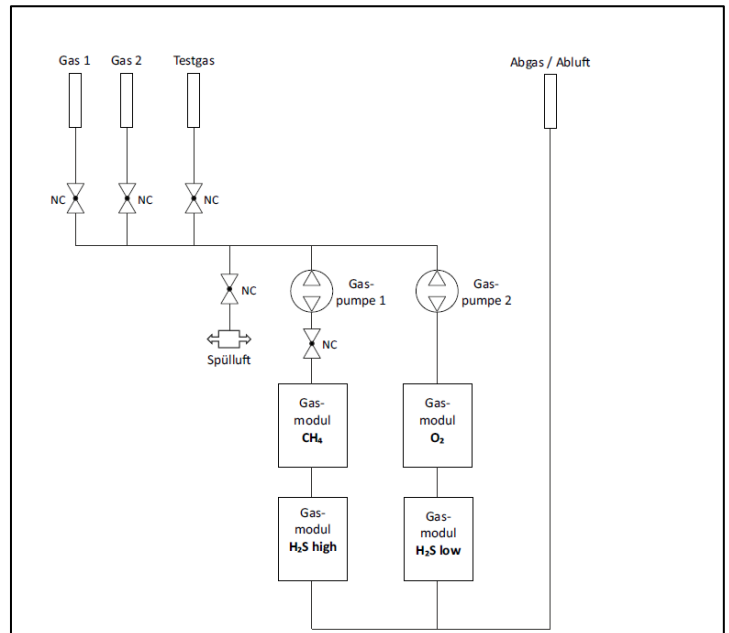

CONTACT

Manuela Charatjan · Dipl.-Ing., Manager Process Engineering · Phone +49 731 18998-0 · Manuela.Charatjan@bindergroup.info
 Binder GmbH · Buchbrunnenweg 18 · 89081 Ulm, Germany · www.bindergroup.info